

# A RATIONALE FOR PROLOTHERAPY

ALLEN R BANKS Ph.D.

*Journal of Orthopaedic Medicine Vol 13 1991 No 3*

---

## INTRODUCTION

Prolotherapy, the technology for strengthening lax ligaments, has found increased acceptance in recent years. However, despite its greater use, the mechanism of action of prolotherapy is not well understood. In the past few years a number of advances have been made in the understanding of wound repair. This author believes the increased knowledge which has been made available in the field of wound healing has application to a more complete understanding of prolotherapy. There follows a general discussion of wound healing and a hypothesis which provides a basis for understanding prolotherapy.

During prolotherapy, proliferating agents are injected directly into stretched or torn ligaments, resulting over a few weeks' time in the loss of pain in the affected area and return to normal function of the associated painful skeletal articulation <sup>1,2</sup>. Following injection of the proliferant, the clinician observes an immediate localized inflammation which diminishes gradually over several days. Patients are cautioned against taking aspirin or other anti-inflammatory agents to relieve the discomfort. Over a period of several weeks or months, the pain with which the patient presented recedes and the treating physician observes a hypertrophied ligament with improved function of the articulation <sup>3,4</sup>. (There is some debate concerning the relationship between mechanical dysfunction and the associated pain of ligaments involved. It is not the purpose of this discussion to venture beyond the biochemical mechanism of prolotherapy ).

How does prolotherapy occur and what is the underlying bio-chemical mechanism? Why is an injured ligament painful if injected with proliferant but an uninjured ligament remains relatively pain-free when injected? Why do non-steroidal anti-inflammatory agents (NSAI), relieve the discomfort so rapidly? Is it reasonable that NSAI should diminish the therapeutic result? What is the purpose of the various mixtures that are used in treatment? How do they achieve their results? In order to answer some of these questions one must first understand, in a general way, how the healing process occurs. (For a more comprehensive description of the inflammatory process and its relationship to wound healing, the reader may consult some references listed at the end of this article).

## WOUND HEALING PROCESS

Figure 1 shows schematically what happens during the healing of an injury <sup>5,6</sup>. Where an injury occurs, cells are sheared and broken open; their contents are spilled into the wound site. Cellular

debris and humoral factors attract an initial influx of granulocytes to the wound site. These cells 'debride' the area through a combination of phagocytosis secretion of lytic enzymes and release of chemical agents such as hypochlorite and peroxide. Attractants for granulocytes may be present in extravasated cellular fluids such as clotted blood or they may be released by injured cells. Many factors associated with cellular injury have been shown to be attractive for granulocytes. They range from thrombolytic peptide fragments, by products of the clotting process, to small chemical messengers derived from cell membrane lipids. Larger proteins found within many cells have been demonstrated to be strongly chemotactic for granulocytes. Whatever the initial chemotactic signal, granulocytes are among the first cells to arrive at an injury site.

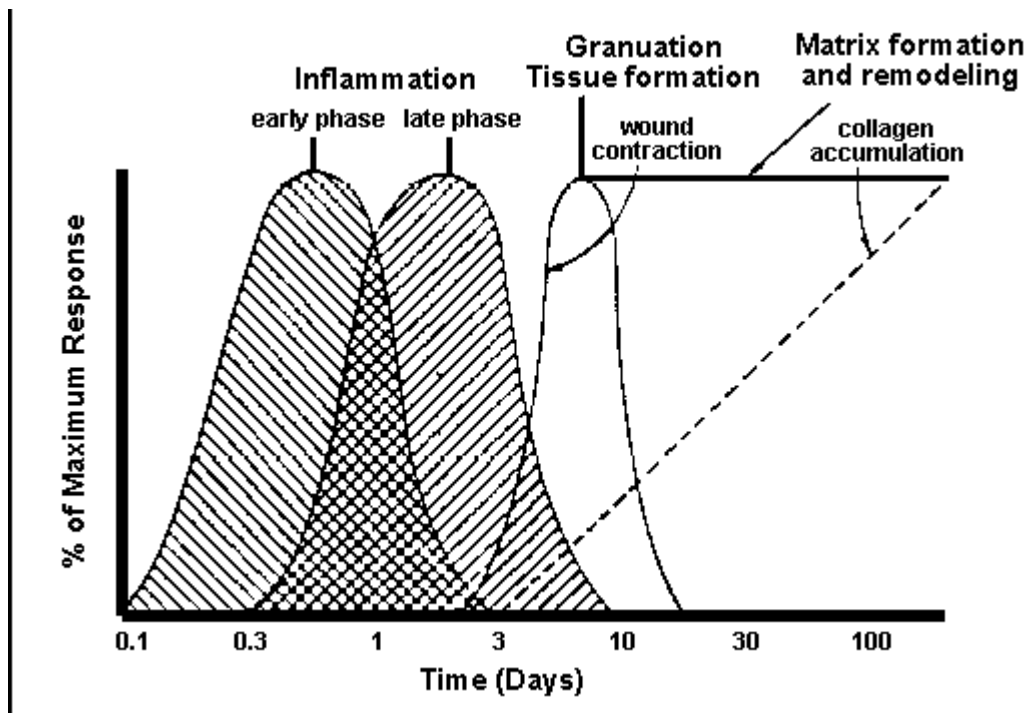

Figure 1

*Summary of Wound Repair*

*Inflammation: early and late inflammation lead to granulation tissue formation. Granulation tissue is rich in fibroblasts and mononuclear cells which result in healing, through a process of matrix deposition and remodeling. The new matrix is composed of collagen and other substances which are accumulated during a period of months, giving added strength to the injury (Clark 1985)*

In addition to secreting chemical debriding agents, granulocytes are known to release their own chemotactic factors which recruit different cells to the injury site. Cells which arrive soon after the granulocytes are monocytes and macrophages. These large phagocytic cells augment the actions of granulocytes, further ridding the injury site of cellular debris and opportunistic pathogens.

The initial phase of inflammation or granulocytosis lasts about three days (which interestingly is approximately the life-time of a granulocyte). During this phase, the second, overlapping, late inflammatory phase begins, involving monocytes and macrophages. The late inflammatory phase; wherein large concentrations of monocytes and macrophages are observed, lasts for a longer period, about ten days. In both the early and late stages of the inflammatory process, polypeptides are secreted which attract fibroblasts to the injury site. Among these factors, chemotactic for fibroblasts, are a number of polypeptide growth factors which have been demonstrated to be synthesized by macrophages. Fibroblasts are recruited to the area by these polypeptide growth factors and are stimulated to produce new intercellular matrix, including new collagen. It is this new collagen which primarily gives strength to the healing wound; de-novo collagen synthesis and deposition is necessary for lasting wound repair.

A soupy indistinct mixture containing granulocytes, macrophages and infiltrating fibroblasts is known as granulation tissue; it is characteristic of a healing wound in the late inflammatory phase. As granulocytes and macrophages phagocytize the injured tissue at the wound site, they simultaneously secrete polypeptide growth factors which attract and activate fibroblasts. Fibroblasts, in turn, deposit new intercellular matrix. Within the healing wound, as time passes, the granulation tissue matures, staining less pink and more blue (with haematoxylin and eosin staining) as more collagen is accumulated.

Ultimately, the granulocytes die and are removed by the macrophages which then slowly leave the wound site, while the fibroblasts remain, secreting a matrix of collagen, peptidoglycan, hyaluronic acid and other substances which increase the integrity of the injury site. Research indicates that there is a continual deposition and dissolution of tissue within the injury site. This "remodeling" process results from the conflicting actions of macrophages and fibroblasts, one enzymatically dissolving intercellular matrix, the other depositing it. The period of matrix formation and tissue remodeling continues for many months after the initial injury. In fact, in animal models, a healed wound does not acquire its maximum strength until about one year after injury, implying that collagen continues to be deposited and reformed for a period of months. This remodeling period may be important for the improved cosmetic appearance of healing wounds with time, allowing the initially less organized collagen to be rearranged into more functional orderly arrays.

In summary, three critical phases occur during the wound healing process: an initial inflammatory reaction which attracts other important cells to the injury site; a secondary inflammatory response in which macrophages secrete humoral factors which attract fibroblasts; subsequently, an infiltration and activation of fibroblasts which lay down new collagen, giving strength to the injury site. This process is called the wound healing cascade and, in the most basic form described above, is characteristic of all healing wounds. It is very important to note that each phase is dependent upon the previous phase for its initiation: tissue trauma leads to an initial influx of granulocytes; a large concentration of granulocytes attracts monocytes and macrophages; macrophages secrete polypeptide growth factors which recruit and activate fibroblasts; fibroblasts deposit the structural materials which repair the wound.

## **COLLAGEN BIOCHEMISTRY**

What happens to the collagen which is deposited at the injury site? Very simply, new collagen shrinks. Collagen (see Figure 2) is synthesized as procollagen, a linear protein with large globular domains at each end of the linear portion <sup>6,7</sup>. (Collagen biochemistry is a complex subject, this discussion is simplified in the interest of clarity). The globular protein domains allow procollagen to remain soluble in cellular fluids. The linear domain is thereby prevented from associating with other procollagen molecules and precipitating from solution before it is exported from the cell.

Once secreted by a fibroblast, however, proteolytic enzymes remove the globular domains, freeing each linear procollagen domain to combine with other linear procollagen domains or, perhaps, other components of the extracellular matrix. Some types of collagen form loose web-like associations with other components of the extracellular matrix. Other types of collagen form more ordered macromolecular associations called tropocollagen; by winding around each other, like strands of rope, they form a triple helical strand of collagen (actually tropocollagen is formed in the golgi prior to export from the cell, with larger scale ordering occurring outside the cell).

The association of three linear procollagen domains to form the tropocollagen triple helix occurs through hydrogen bonding. As one procollagen strand binds to two other procollagen protein strands, forming the characteristic collagen triple-helix, the water molecules which previously solubilized the polypeptide strands are replaced by protein-protein hydrogen bonds; water is excluded from the spaces between the linear polypeptide domains. At this point, the collagen triple helices, now outside the cell, combine with others in the extracellular matrix and by a form macromolecular fibrils. As time passes, more water is excluded by these string protein-protein interactions. During this dehydration process, the protein becomes more compact. In addition, the fibrils become chemically crosslinked, permanently bonding to one another. As the fibrils crosslink, they become hard almost crystalline. They lose even more water. They become the white acellular semicrystalline material which we observe in ligaments and tendons. The exclusion of water by protein-protein hydrogen bonding brings about a collapse of the hydrated structure of the polypeptide which was previously solubilized; the protein occupies less space, it becomes smaller. If the new collagen is in a ligament, the ligament shrinks; it shortens as the intermolecular spaces collapse upon the spaces previously occupied by solvent.

Anyone who has seen the skin contract around a healing skin wound has observed that new collagen contracts during the late stages of healing. (Some other processes are active in the dermal intercellular matrix, including the production of myofibrils by myofibroblasts which assist wound contraction; these processes may occur within ligaments also). Contraction occurs at any site where new collagen is produced, even within ligaments. This is the main point to remember in our discussion of collagen.

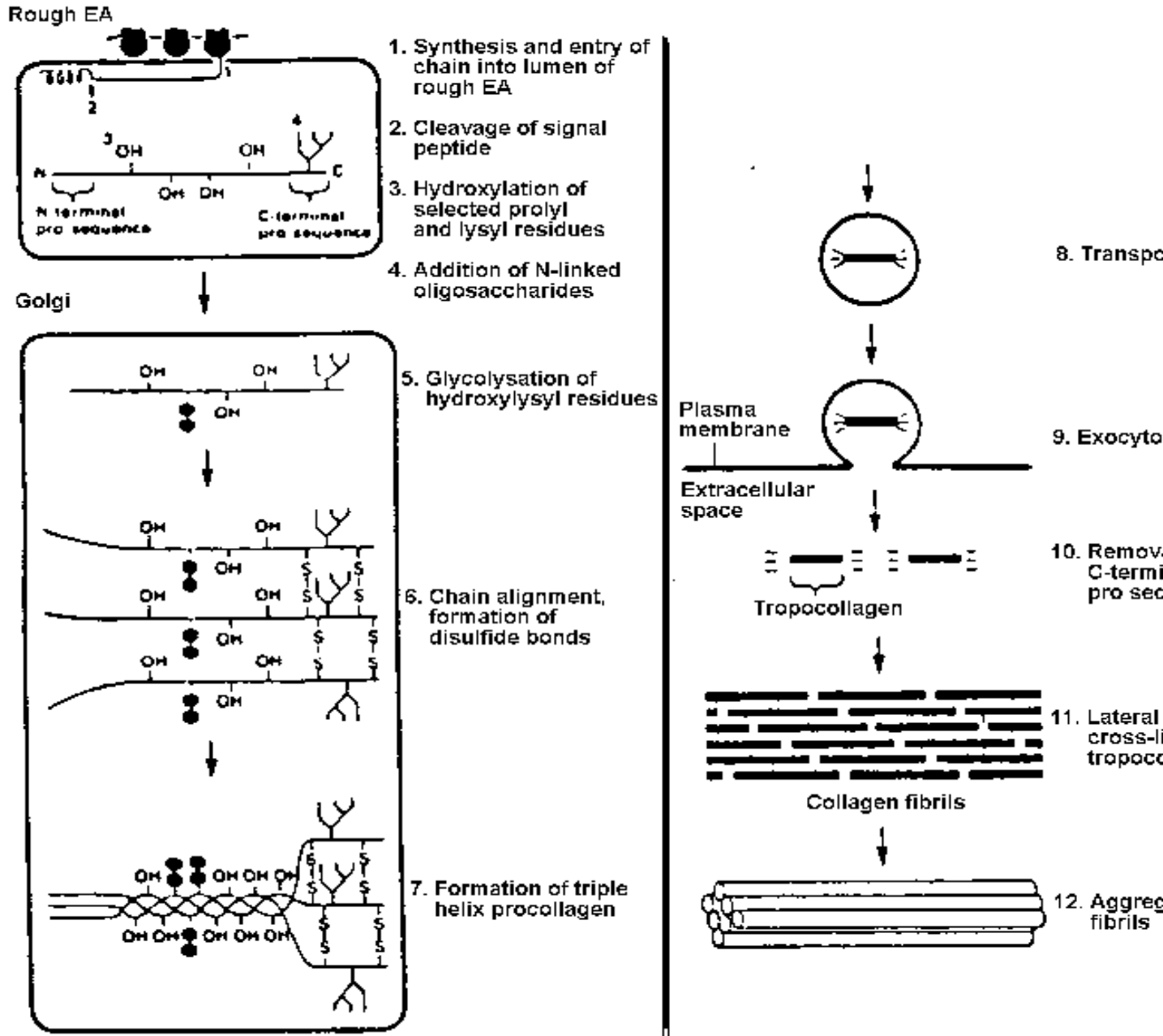

Figure 2

### Collagen biosynthesis

*Collagen in the extracellular matrix forms strong compact bundles of fibrils. These fibrils are constructed from tropocollagen units formed in the Golgi from the association of three procollagen polypeptide strands.*

*(Carnell, Lodish and Baltimore 1986)*

### PROLIFERANTS

Now we can discuss the proliferants. Most basically, proliferants used for prolotherapy are substances injected into a ligament which lead to new collagen formation. The way that they do this is by initiating the first step in the wound healing cascade discussed: they cause local inflammation. Once the inflammation has begun and granulocytes and macrophages have been attracted to the injection site, fibroblasts will surely follow and deposit new collagen. The new collagen that is produced at the injection site undergoes contraction and pulls the ligament tighter. Proliferant solutions vary in the mechanism by which they cause localized inflammation but, in general, they all act by causing localized tissue trauma or irritation which initiates an influx of inflammatory cells. The exception to this rule is sodium morrhuate which may act as a chemotactic factor by a more direct mechanism. Perhaps, even more simply, proliferants are "inflammatory agents" which, by initiating the first step in the wound healing cascade, lead to fibroplasia.

## IRRITANTS

The first class of proliferant solutions, called irritants or haptens, are exemplified by phenol, guaiacol and tannic acid. These substances are found for example in P2G (P25G) and plasma-QU. Each of these compounds has phenolic hydroxyl groups which are readily oxidized to produce reactive quinone-like compounds (see Figure 3) which are known to directly alkylate the proteins on the surfaces of cells. By attaching themselves or their quinonoid oxidation products to the surfaces of cells at the injection site they either damage the cells directly or render them antigenic. In either case, granulocytes and macrophages are attracted to the injection site and early inflammation occurs; in other words, the wound healing cascade is initiated.

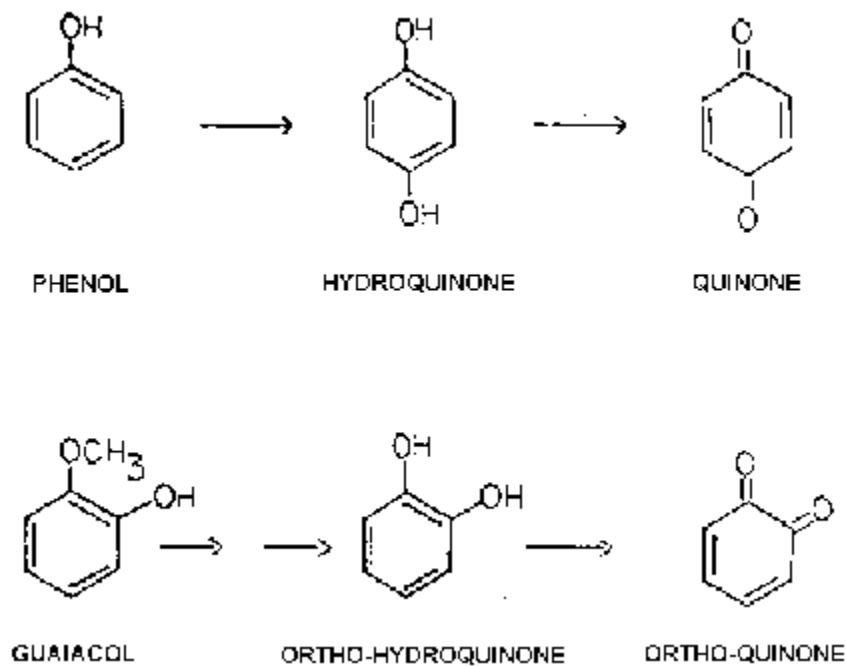

*Figure 3*  
*Irritants*

*Agents with phenolic hydroxyl groups oxidize spontaneously to reactive quinoid compounds capable of alkylating cells.*

## **Particulates**

Particulates such as pumice flour are irritants of a different type. Small particles, on the order of 1 micron (about the same size as bacteria), are noted for their ability to attract macrophages. The macrophages phagocytize small particles in the same way in which they ingest bacteria and cellular debris. This is the principle upon which cell sorters are used to separate macrophages from other cells; the macrophages are allowed to ingest magnetic particles and are then separated from other cells by a magnetic field. Once the macrophages arrive at the injection site, ingesting the pumice granules, they likely secrete polypeptide growth factors which result in fibroplasia and new collagen deposition. Granulocytes also may be attracted to the cellular trauma caused by injection of particulates.

## **OSMOTICS**

A second class of proliferants is characterized by osmotic shock. These agents act by dehydrating cells at the injection site. In osmosis, concentrated solutions cause a net flow of solvent across a semipermeable membrane from solutions which are less concentrated. In our case, the less concentrated solution is that found within living cells and the semi-permeable membrane is the cell membrane; the more concentrated solution, the osmotic proliferant, causes a net flow of water into the injection site by removing water from living cells. Upsetting the delicate balance within these living cells causes severe, but localized, tissue trauma. No doubt many of the cells at the injection site are killed. Cells at the injection site, which are either morbid or dead, release cellular fragments (proteins, membrane fragments and the like) which are attractive for granulocytes and macrophages. Thus, local tissue damage causes an influx of inflammatory cells and initiates the wound healing cascade. Osmotic proliferants, concentrated solutions of simple water soluble compounds, include concentrated glucose, glycerin or zinc sulfate. (Zinc sulfate may have other activities such as metallation of certain cellular proteins, causing secondary cellular injury; zinc binds very strongly to certain functional groups on proteins, particularly the sulfhydryl groups of cysteine. Glucose may have secondary effects as well. For example, it is known that in diabetics high local glucose concentrations lead to non-specific glycosylation of some cellular proteins).

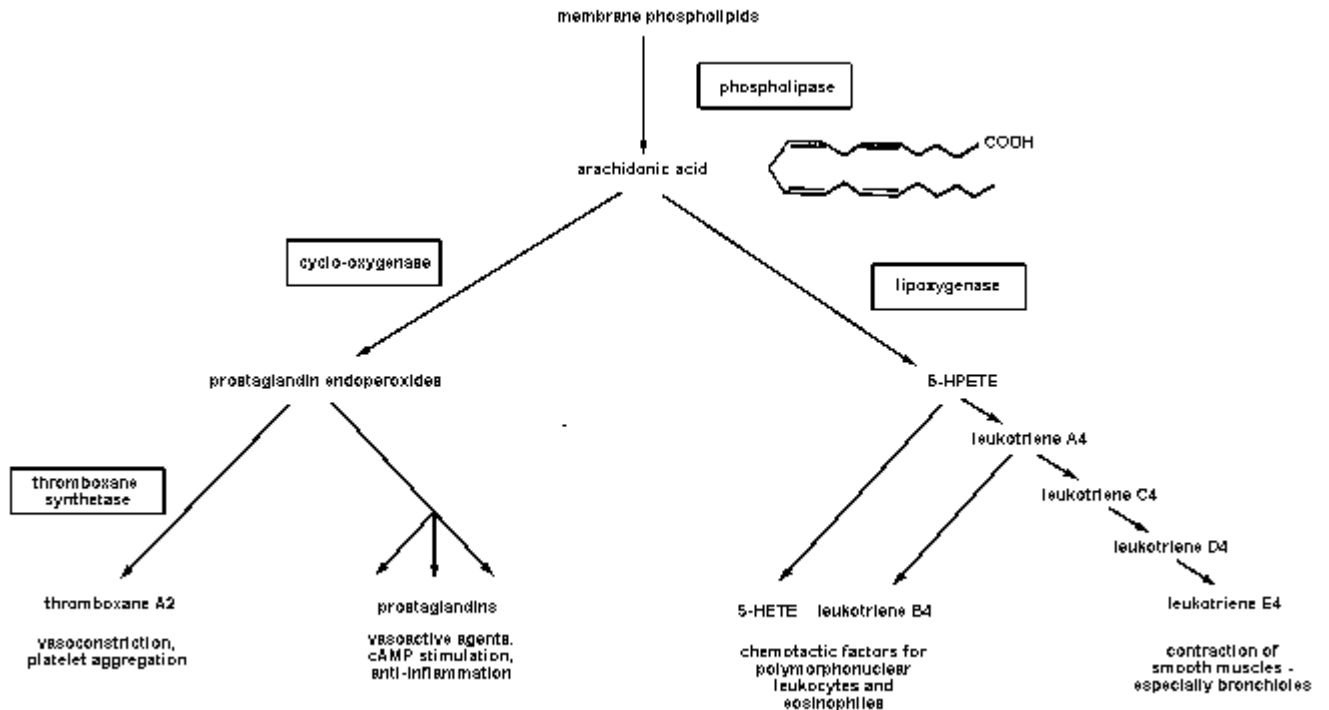

Figure 4

*Arachidonic acid and its metabolites*

*Metabolites of arachidonic acid, a normal component of the cell membrane, are important mediators of the inflammatory process (Hood, Weissman, Wood and Wilson 1984)*

**CHEMOTACTICS**

A third class of proliferants only has one member currently; sodium morrhuate contains the biosynthetic precursor to certain chemotactic agents which attract inflammatory cells 8.9. Sodium morrhuate is the sodium salt of the fatty acid component derived from cod liver oil. Cold water fish oils are rich in polyunsaturated fatty acids such as arachidonic acid and related 20 carbon polyunsaturated fatty acids 10. (see Figure 4). These compounds are direct biosynthetic precursors to the mediators of inflammation such as prostaglandins, leukotrienes and thromboxanes 11. Cells use these compounds to communicate with other cells. For example, tissue trauma is thought to lead to the production of prostaglandins which promote vasoconstriction and swelling within the local area as well as attract granulocytes. It is thought that both the identity of the compounds produced and their concentration are important for intercellular communication. The documented powerful proliferant action of sodium morrhuate may be due to its arachidonic acid component being directly converted into prostaglandins and related mediators of inflammation. The observation that aspirin or ibuprofen (powerful inhibitors of key enzymes in prostaglandin biosynthesis) immediately eliminates the discomfort of sodium

morrhuate injection corroborates this hypothesis. Synasol may act similarly: the polyunsaturated fatty acid component being contributed by a plant extract rather than coming from marine oils.

### **Example: 20% Glucose Solution**

As an example of one of these solutions, let us see what happens in the course of treatment with 20% glucose. Upon introduction at the injection site, the high osmolarity of 20% glucose immediately causes a new flow of water out of cells across their cell membranes into the immediate vicinity of the injection site. The cells at the injection site become as flaccid and dehydrated as if they had been exposed to the air. These compromised cells become morbid and may eventually die. When cells are osmotically shocked, or upon cell death, the integrity of the cell membrane is lost and factors are released which attract granulocytes, including fragments of cellular proteins and other cellular debris. Those cells not killed immediately release prostaglandins, leukotrienes and thromboxanes, the effects of which are to attract inflammatory cells and to isolate the injury site via vasoconstriction. These small molecular weight mediators of inflammation are derived from the cell membrane fatty acid, arachidonic acid.

Arachidonic acid and closely related 20 carbon polyunsaturated carboxylic acids are transformed by an enzymatic process into a number of inflammatory compounds, including the prostaglandins, leukotrienes and thromboxanes. These biosynthetic derivatives of arachidonic acid are important chemical messengers used by cells for communication. Certain enzymes in the biosynthetic process can be inhibited selectively, eliminating the production of many of these inflammatory mediators. For example, aspirin, acetyl salicylic acid, inhibits the enzyme cyclooxygenase which carries out a key biosynthetic step in the prostaglandin synthetic pathway. This is the origin of aspirin's ability as a pain reliever. Inflammation is painful; eliminate the inflammation and the pain is relieved.

If inflammation is the first step in the healing response, then anything which interferes with the inflammatory response inhibits healing. Many practitioners of prolotherapy have observed that aspirin or ibuprofen immediately eliminates the discomfort associated with prolotherapy but that the clinical result is correspondingly diminished. The ability of non-steroidal anti-inflammatory agents to inhibit the healing response has been well-documented in experimental situations and has been observed clinically <sup>12</sup>.

To continue, the first biochemical step generated by using 20% glucose is localized tissue trauma, based upon osmotic shock, which initiates an inflammatory reaction, the first step in the wound healing cascade. Granulocytes, attracted to the injection site by cellular debris and chemotactic agents like prostaglandins, begin to chemically 'debride' the injection site and, during the process, secrete humoral factors chemotactic for macrophages. The macrophages phagocytize cellular debris and dying granulocytes, simultaneously secreting polypeptide growth factors which recruit and activate fibroblasts. The fibroblasts infiltrate the injection site and begin to secrete new collagen which, over time, forms a stronger, tighter, thicker ligament, through a process of crosslinking and dehydration. Photomicrographs of histologically prepared samples taken from injection sites confirm that granulation occurs at the prolotherapy injection site <sup>1,2,3,4,8,9</sup>.

An interesting secondary effect of concentrated glucose solutions stems from the known ability of glucose, at higher than normal concentrations (for example in diabetics), to glycosylate tissues and make them appear foreign to the immune system. This non-specific process, if it occurs at the prolotherapy injection site, would be expected to be immunogenic, inducing a localized inflammatory reaction. Such a mechanism also may be operating when 20% glucose is used as a proliferant. Whatever the initiating mechanism, the subsequent inflammatory reaction and the consequent wound healing cascade lead to fibroplasia in due time.

A third possible explanation for the action of concentrated glucose may be that it provides a gradient of a desirable nutrient which attracts mobile cells of the body's repair apparatus to the injection site. Most cells use glucose for energy and cells of the immune system may well be attracted to this locally concentrated energy supply.

## **SUMMARY AND CONCLUSIONS**

In summary then, the basic mechanism of prolotherapy is not so difficult to understand, once the wound healing process is understood. Proliferants are injected which initiate local inflammation. The inflammation launches a wound healing cascade resulting in the deposition of new collagen and a hypertrophied ligament. New collagen loses volume and contracts as it matures. The hypertrophied ligament is not only more robust but also, paradoxically, tighter due to the contraction which occurs with recently deposited collagen.

Why was the proliferant treatment needed if inflammation (following the initial injury) is naturally followed by repair? Perhaps the repair was incomplete following the initial injury or perhaps modern medical treatment interfered with natural healing. Many clinicians advise their patients presenting with recent trauma, back pain or other joint pain to take anti-inflammatory drugs. In light of what we know about wound healing in general, it may not be advisable to interfere with local inflammation immediately following a ligament injury. With inflammation, the necessary sequelae which culminate in healing may not be initiated.

We now know that agents which inhibit inflammation also inhibit the wound healing cascade. Recent research has detailed the inhibiting effects of aspirin and related drugs upon healing. To attain a thorough initial inflammatory reaction, patients might profitably avoid commonly prescribed anti-inflammatory agents: steroids, aspirin or other non-steroidal anti-inflammatory agents. A robust initial inflammatory phase leads to a corresponding infiltration of fibroblasts, the cells which produce collagen, the major strengthening agent in a healed injury.

Non-steroidal anti-inflammatory agents are most often prescribed because they are thought to be a safe and conservative treatment modality. However, research has shown that non-steroidals are not without side effects. In addition to their well documented adverse effects upon healing in the alimentary tract, they may directly inhibit healing of injured ligaments. It is well-accepted that prostaglandins, the target of non-steroidal anti-agents, are mediators of many important physiological processes in addition to their roles in the wound healing cascade. They are, quite simply, part of the chemical language used for intercellular communication. Interference in such important physiological processes (for example, the control of smooth muscle contraction) may be without consequences. Though they are not now completely understood, the widespread

function of prostaglandins and related metabolites of arachidonic acid cautions against indiscriminate systemic inhibition of their biosynthesis.

The associated pain of the initial injury or the related discomfort of prolotherapy, which in an artificial way reintroduces the inflammation of the initial injury, is an important signal that healing is underway. Analgesics are available which reduce pain without direct interference in the inflammatory process. Such analgesics might be better employed in situations where a wound healing response is desired.

At some point in the future, chemotactic factors and polypeptide growth factors, produced by genetic engineering technology, will become available to the clinician<sup>5,13</sup>. When this occurs, clinicians may be able to recruit fibroblasts directly to an injured ligament and perhaps avoid the discomfort of an inflammatory response. Until these days arrive, the astute clinician can stoically recite the old dictum that nothing worth achieving is obtained without sacrifice. Or in other words, proper healing does not occur without a certain amount of inflammation and discomfort.

## **REFERENCES**

1 GS Hackett Ligament and Tendon Relaxation (Skeletal Disability) Treated by Prolotherapy (Fibro-Osseous Proliferation) Charles C Thomas Publishers Springfield, Illinois 3rd Edition 1958

2 GS Hackett and DG Henderson Joint stabilization: an experimental, histologic study with comments on the clinical application in ligament proliferation Am J of Surg 80 968- 973 (1955)

3 MJ Ongley, RG Klein, TA Dorman, BC Eek and LJ Hubert A new approach to the treatment of chronic low back pain The Lancet July 18 143-146 (1987)

4 RC Klein, TA Dorman and CE Johnson Proliferant injections for low back pain: histologic changes of injected ligaments and objective measurements of lumbar spine mobility before and after treatment J of Neurol and Ortho Med and Surg 10:2 123-126 (1989)

5 The Molecular and Cellular Biology of Wound Repair Eds:RAF Clark and PM Henson Plenum Press, New York (1988)

6 RAF Clark Cutaneous tissue repair: basic biologic considerations I J of Am Acad of Derm 13 701-725 ( 1985)

7 J Damell, H Lodish and D Battimore Molecular Cell Biology Scientific American Books New York (1986)

8 YK Liu, CM Tipton, RD Matthes, TG Bedford, JA Maynard and HC Walmer An in situ study of the influence of a sclerosing solution in rabbit medial collateral ligaments and its junction strength Connective Tissue Research 11 95-102 (1983)

9 JA Maynard, VA Pedrini, A Pedrini-Mille, B Romanus and F Ohlerking Morphological and biochemical effects of sodium morrhuate on tendons J of Orth Research 3 236-248 ( 1985)

10 HN Brocklesby Structure of component acids and composition of marine animal oils Section 2 in: Fisheries Board of Canada Bulletin No LIX The Chemistry and Technology of Marine Animal Oils with particular reference to those of Canada Ed:HN Brocklesby Ottawa (1941 )

11 LE Hood, IL Weissman, WB Wood and JH Wilson Immunology The Benjamin Cummings Publishing Company Menlo Park, California ( 1984)

12 JA Oates, GA Fitzgerald, RA Branch, EK Jackson, HR Knapp and LJ Roberts Clinical implications of prostaglandin and thromboxane A<sub>2</sub> formation The New England J of Med 319:11 689-698 ( 1988)

13 JP Thompson, TR Oegema Jr and DS Bradford Stimulation of mature canine intervertebral disc by growth factors Spine 16 253-260 (1991 )

---

*Originally published in the Journal of Orthopaedic Medicine Vol 13 1991 No 3*